

plan showing the proposed construction of factory building at s.No. 107/2, plot no.10, of okkiam thorappakkam village, saidapet tk, st.thomas mount pt union, chengai m.g.r. district.

SCALE: 1"=8'-0" (1:100) (MANUFACTURING OF PLASTIC COMPONENTS & TOYS)

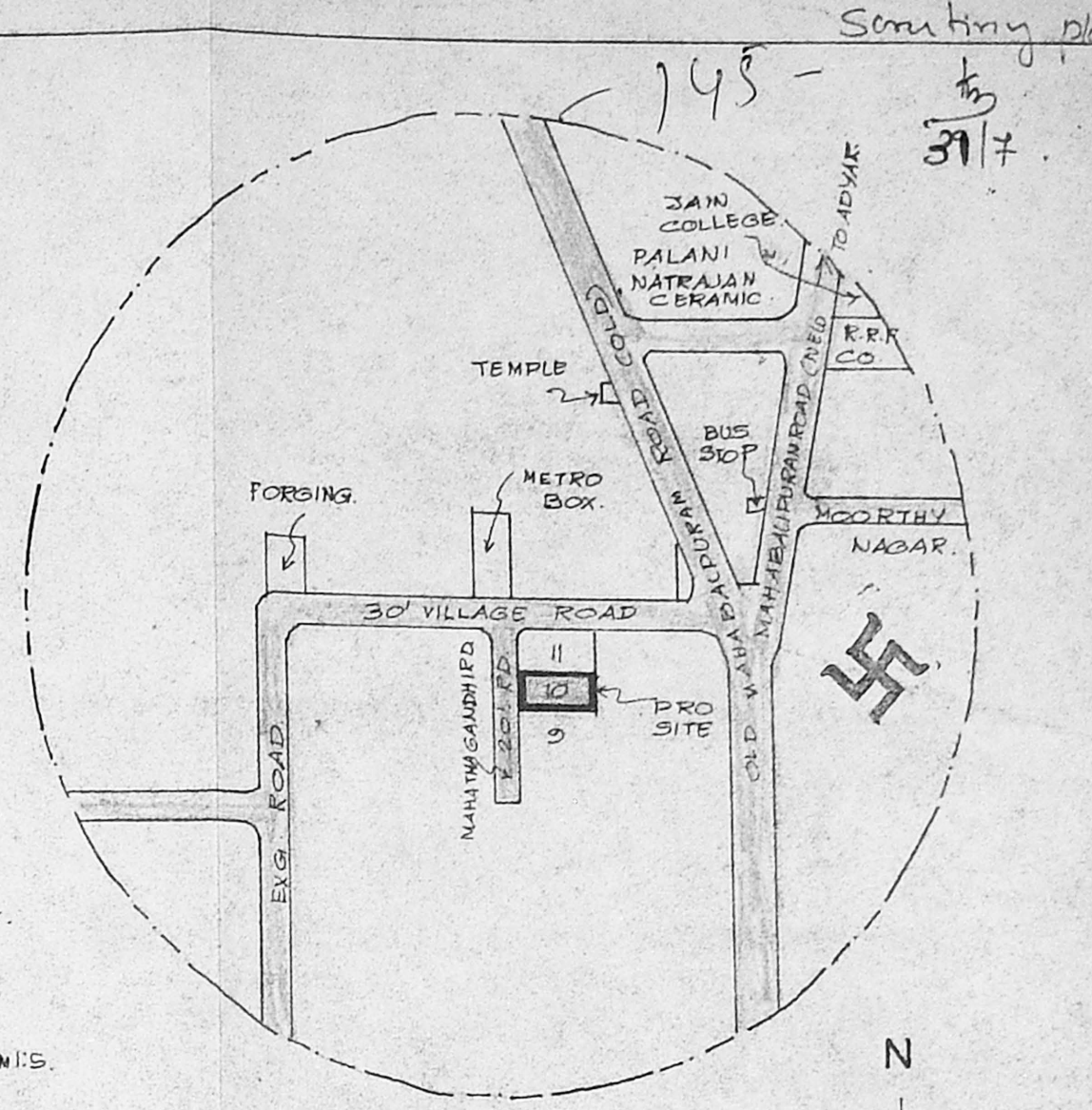

key plan
NOT TO SCALE.

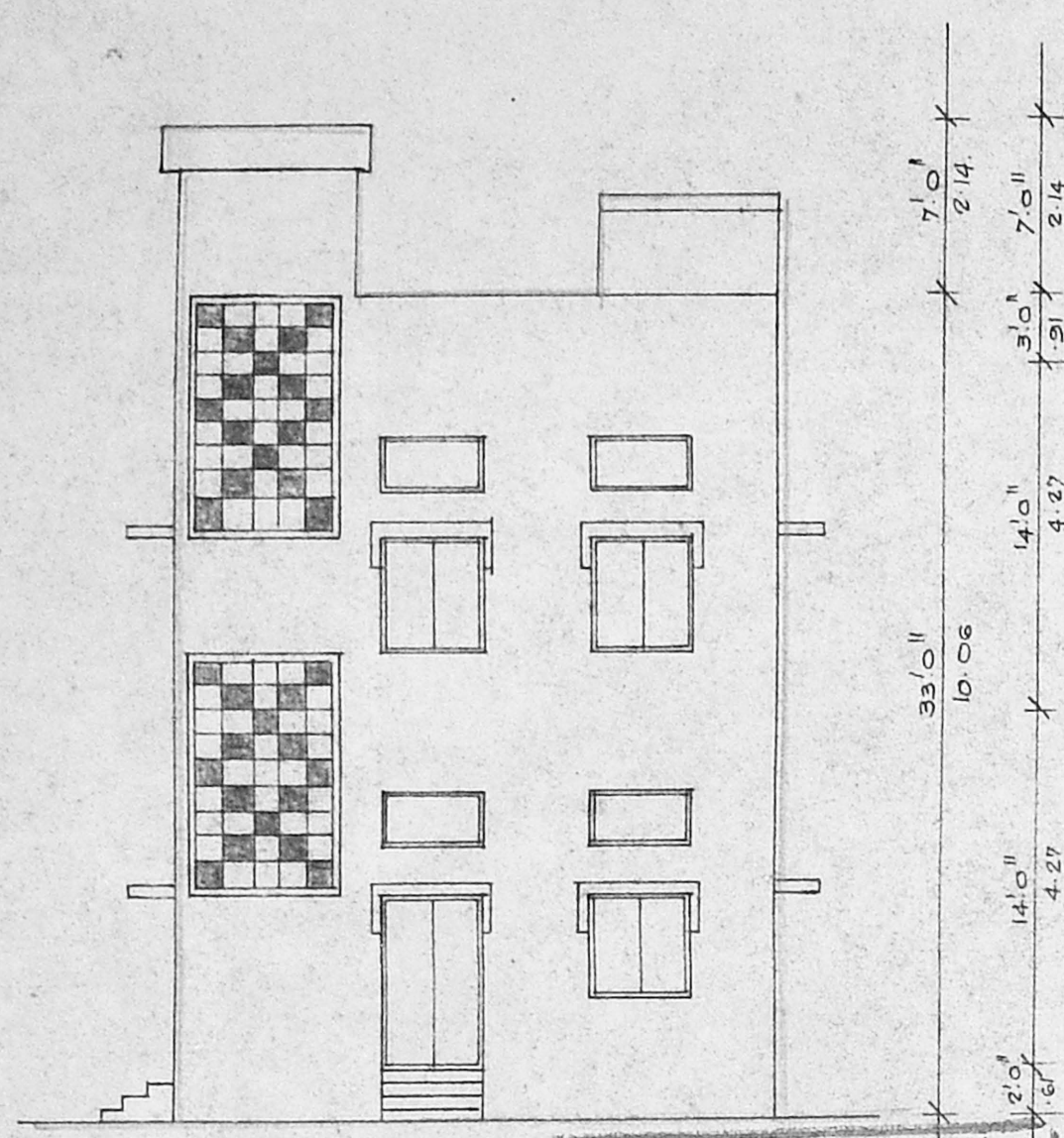

elevation

Planning Permit No. C/PP 137/95
APPROVED
 SUBJECT TO THE CONDITIONS IN THIS OFFICE LETTER.
 No. C/19170/95 Date: 7-9-95
 FOR MEMBER SECRETARY
 MADRAS METROPOLITAN DEVELOPMENT AUTHORITY
 MADRAS - 600 008.

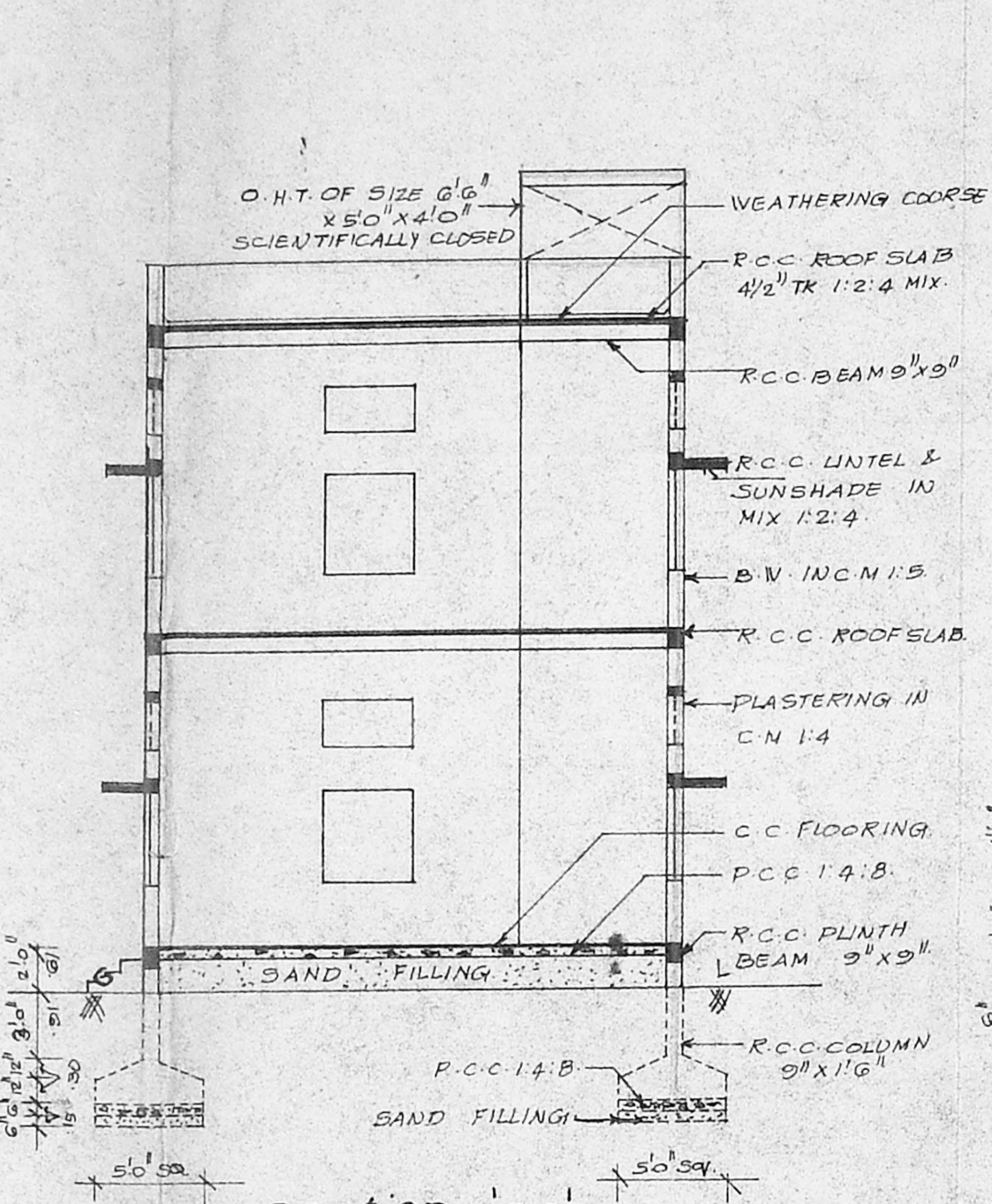

section 'aa'

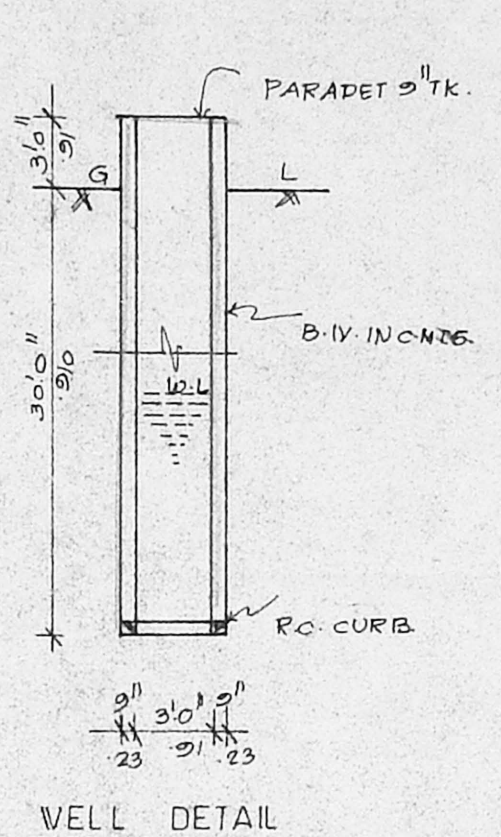

WELL DETAIL

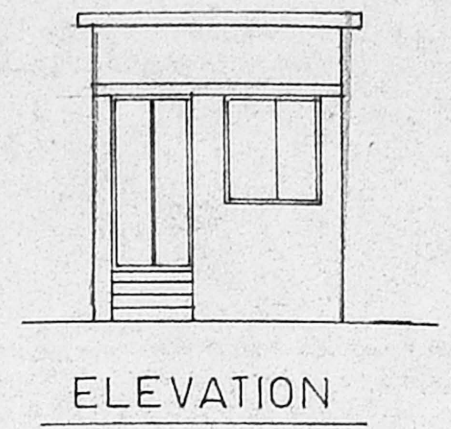

ELEVATION

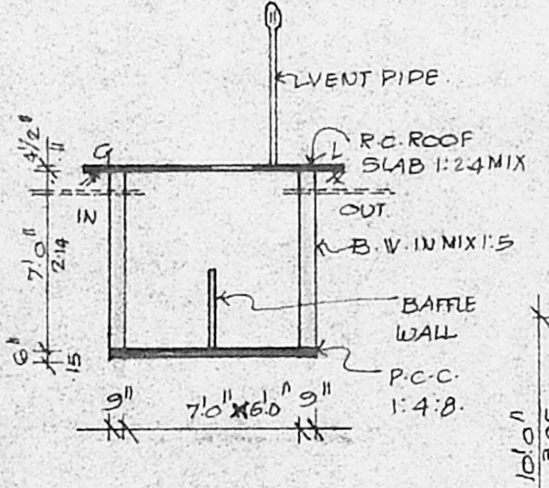

SEPTIC TANK DETAIL

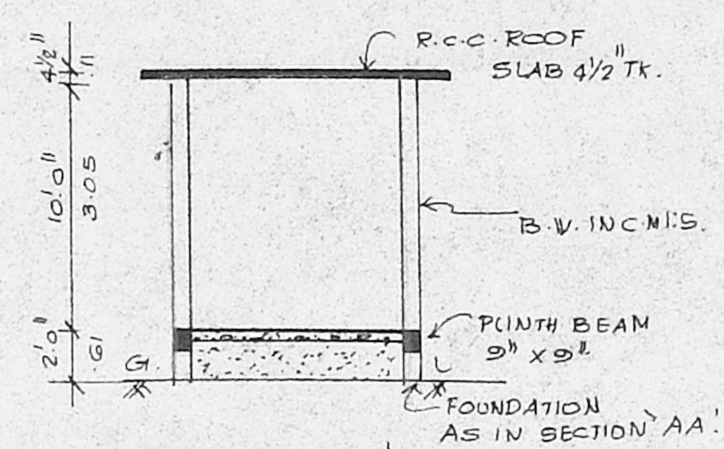

SECTION - B B

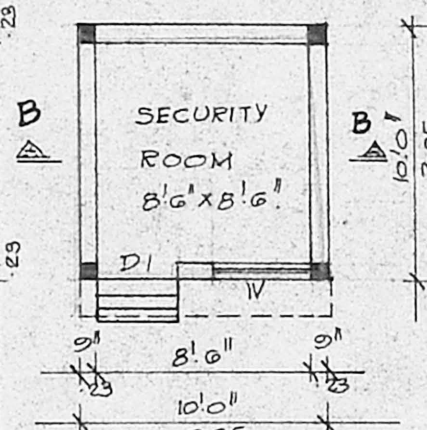

PLAN

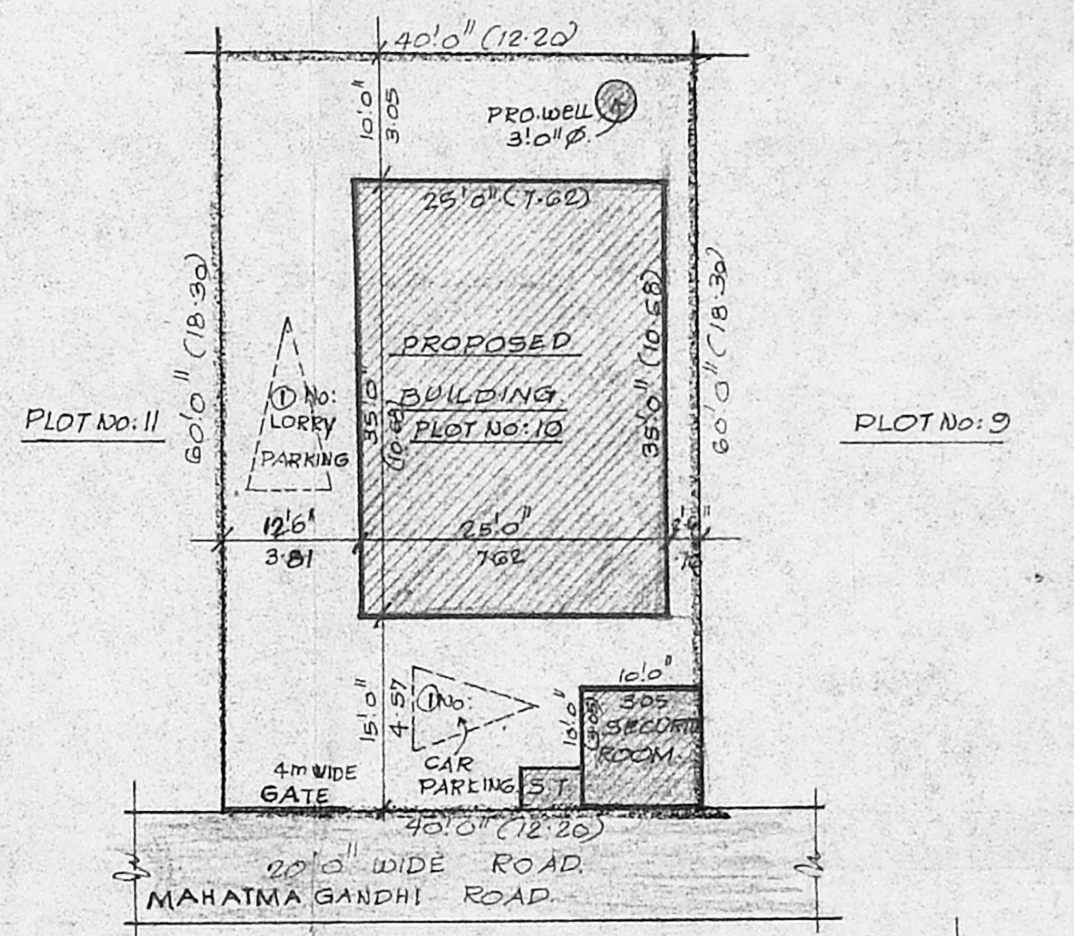

site plan
SCALE: 1"=16'-0" (1:200)

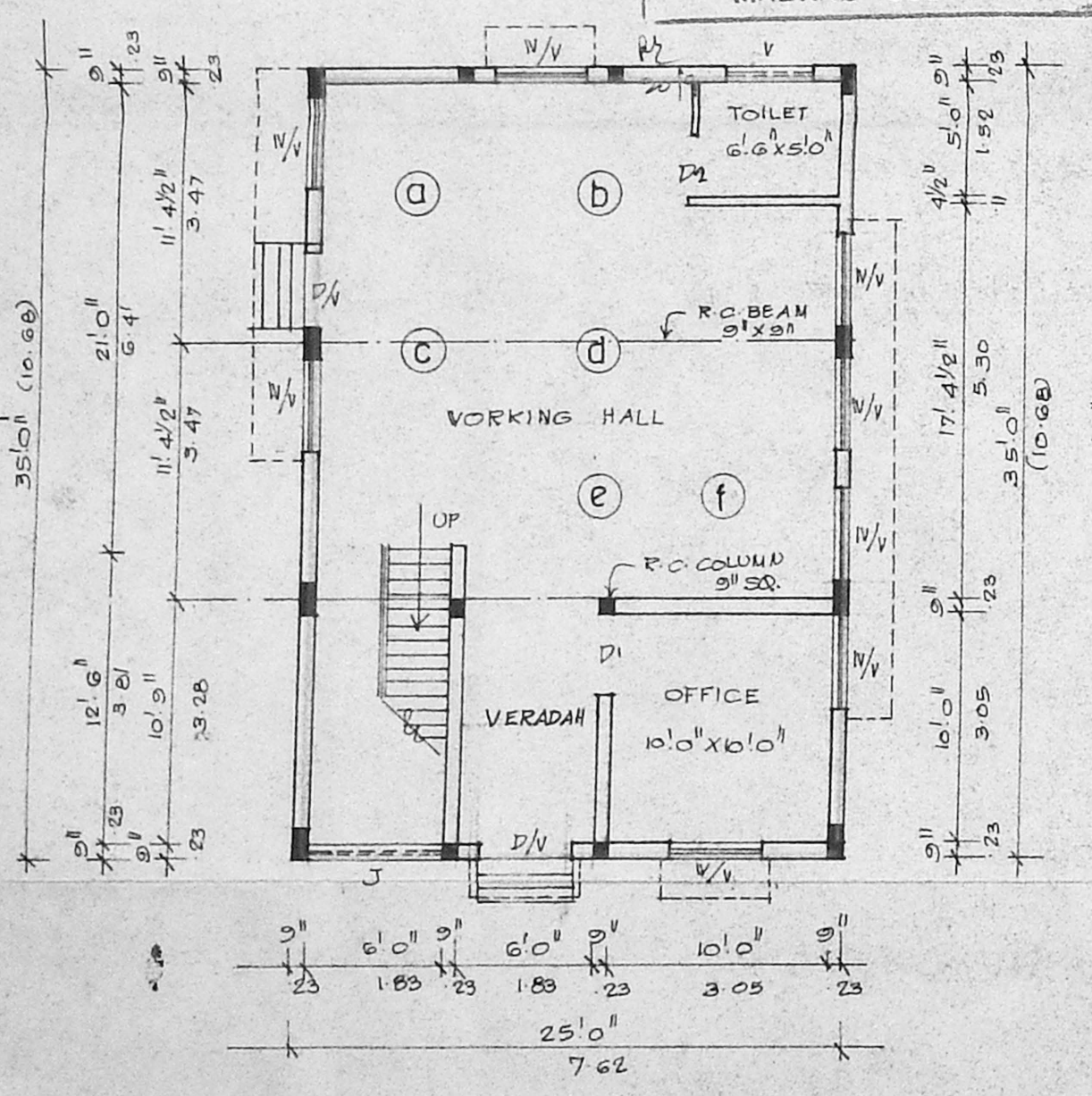

ground floor plan

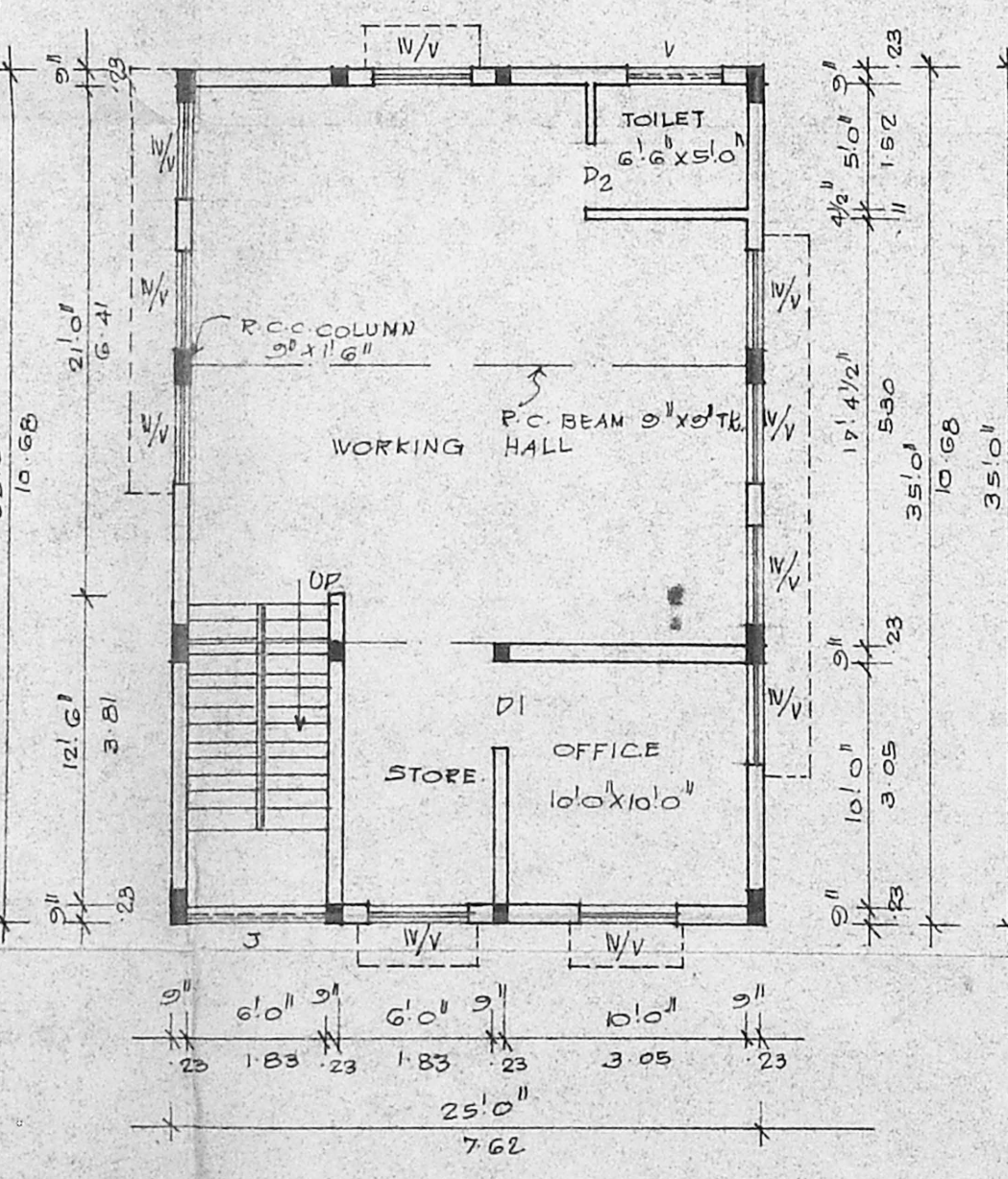

first floor plan

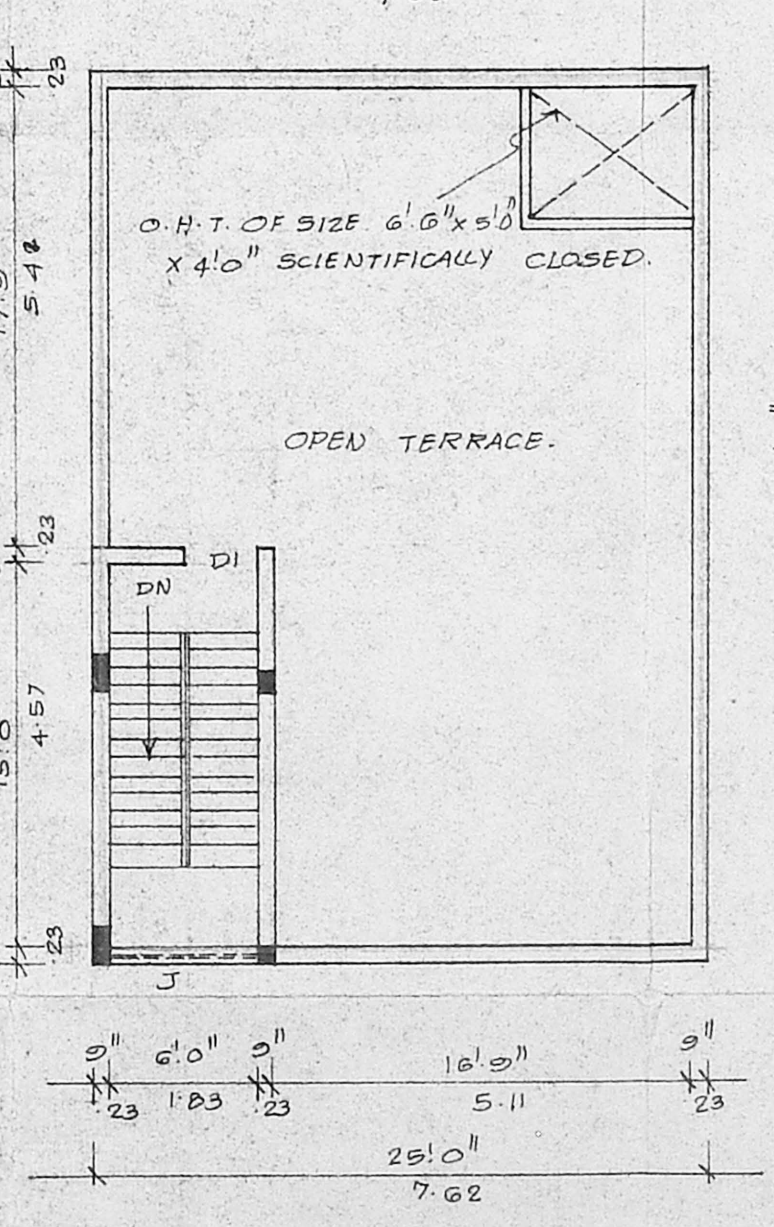

terrace floor plan

JOINERIES		MACHINERIES	
D	DOOR 4'0" x 7'0" (1.22 x 2.14)	(a)	PLASTIC INJECTION MOULDING. 2 NOS. 10.0
DI	DOOR 3'3" x 7'0" (1.0 x 2.14)	(b)	PLASTIC GRINDER 3.0
D2	DOOR 2'6" x 7'0" (0.76 x 2.14)	(c)	PLASTIC EXTENDER 5.0
W	WINDOW 4'0" x 4'6" (1.22 x 1.37)	(d)	LATHE 3.0
V	VENTILATOR 4'0" x 2'0" (1.22 x 0.61)	(e)	DRILLING MACHINE 1.0
J	R.C.C. JOLLY. 6'0" WIDE. (1.83 WIDE)	(f)	MILLING MACHINE 3.0
		TOTAL No. OF WORKERS = 7 NOS.	

LEGEND		AREA DETAIL	
PROPOSED	[Symbol]	PLOT AREA.	2400 SFT. 222.36 M ²
ROAD	[Symbol]	PRO. G.F. AREA.	875 SFT. 81.29 M ²
BOUNDARY.	[Symbol]	PRO. F.F. AREA.	875 SFT. 81.29 M ²
		SECURITY AREA.	100 SFT. 9.29 M ²
		TOTAL AREA.	1850 SFT. 171.87 M ²
		COVERAGE =	40% F.S.I. = 0.77

OWNER

R. Pagutharivu
R. PAGUTHARIVU, D.C.E., D.C.T.,
 LICENSED SURVEYOR.
 CORPORATION OF MADRAS.
 REG. NO. 96
 Office: 10, Venkateshwara Avenue,
 SABARI NAGAR, FORUR-116
 LICENSED SURVEYOR